

## FM/1 Series Time Switches



### TECHNICAL DATA

- Supply Voltage: Synchronous: 24, 120 and 240VAC, 60Hz  
Quartz: 24V AC/DC, 120 and 240VAC 50/60 Hz
- Switch Type: SPDT
- Switch Rating: 21A @ 250VAC resistive  
1350 watt tungsten  
1HP @ 125VAC  
2HP @ 240VAC
- Ambient Temp. Range: -40°F to 180°F, synchronous units  
-20°F to 140°F, quartz units
- Terminals: 1/4" spade terminals
- Reserve Carryover: 7 days for quartz units
- Weight: Approximately 3 oz.
- Agency Approvals: UL Recognized

**NOTE:** 24V quartz unit will operate on 6VDC, 12VDC, or 24VDC

### APPLICATIONS

The FM/1 series of time switches are designed for control of heating, ventilating, air conditioning, refrigeration, lighting, security, circulating pumps, spas or any electrical load requiring 24-hour or 7-day scheduling.

### WIRING

Verify input voltage stated on back of unit. Use 1/4" quick connects and make connections in accordance with the wiring diagram shown and applicable code requirements. When using 24V units, it is important to use transformers that will supply the required 24 volts AC to terminals 1 & 2.

#### Terminal Connections

Contacts shown in "Off" position (trippers pushed inward)  
"On" position (trippers pushed outward) will close contacts 3 & 4

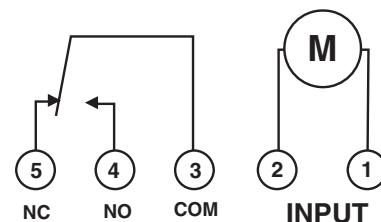

### MOUNTING

The standard FM/1 units can be flush mounted (mounting kit with screws available) or surface mounted inside a panel. A printed circuit board mounting base is also available. An indoor or outdoor enclosure is available for stand-alone mounting. In addition, unit is also available in DIN housing for flush or surface mounting (see MIL72, Digi 20 or Digi 42 data sheets). Optional clear plastic dust cover is available.

## Dimensions

FM/1 synchronous/quartz

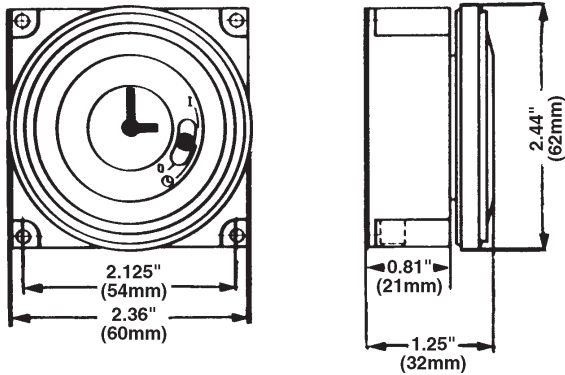

## TIME SETTING

**TO SET THE CURRENT TIME (AND DAY OF WEEK ON 7 DAY UNITS), TURN THE MINUTE HAND CLOCKWISE. DO NOT SET THE TIME BY ROTATING "OUTER" DIAL.**

Turn the minute hand clockwise until the day of the week (7-day timer) and the time of day on the outer dial is aligned with the triangle marker on the inner dial (two o'clock position).

Example for 7-day program dial Monday 10:30 AM. Turn the minute hand clockwise until Monday 10:30 AM is aligned with the triangle on the inner dial. The hour and minute hand will show exactly 10:30.

Example for 24-hour program dial 10:30 AM. Turn the minute hand clockwise until 10:30 AM is aligned with the triangle on the inner dial. The hour and the minute dial will show exactly 10:30.

## PROGRAMMING

### 7-Day (SW, QRW Models)

The weekly program dial reflects the seven days of the week and AM/PM imprints for each day.

The time switch is programmed by pushing the captive trippers to the outer ring position for the entire period that the load is to be turned "ON", i.e., two hours for each tripper on the 7-Day dial. When the tripper is pushed to the inside, the switch is in the "OFF" position.

### 24-Hour (ST, QRT Models)

The 24-Hour dial has quarter-hour divisions and AM/PM indications.

The time switch is programmed by pushing the captive trippers to the outer ring position for the entire period that the load is to be turned "ON", i.e., fifteen minutes for each tripper on the 24-Hour dial. When the tripper is pushed to the inside, the switch is in the "OFF" position.

## PROGRAMMING WITH MANUAL OVERRIDE SWITCH

### AUTOMATIC MODE

In order to operate the time switch module in the automatic mode, the manual switch must be in the center position (automatic) - see diagram.

### MANUAL MODE

With the manual switch selector lever the selected programs can be overridden. In the lower position, marked "O", terminals 3 and 5 are permanently closed. In the upper position, marked "I", terminals 3 and 4 are permanently closed (see diagram).

## Override Mode

3-way manual  
override switch

I = permanent ON  
⌚ = automatic  
O = permanent OFF

